

1 2 3 4 5 6 7

A A

B B

C C

D D

E E

F F

G G

H H

1 2 3 4 5 6 7

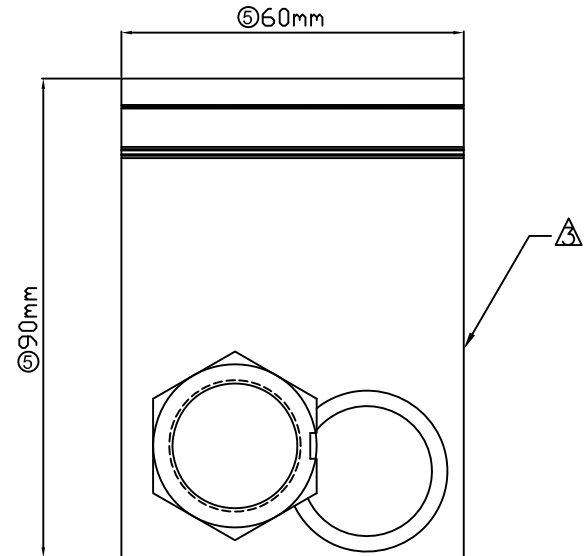
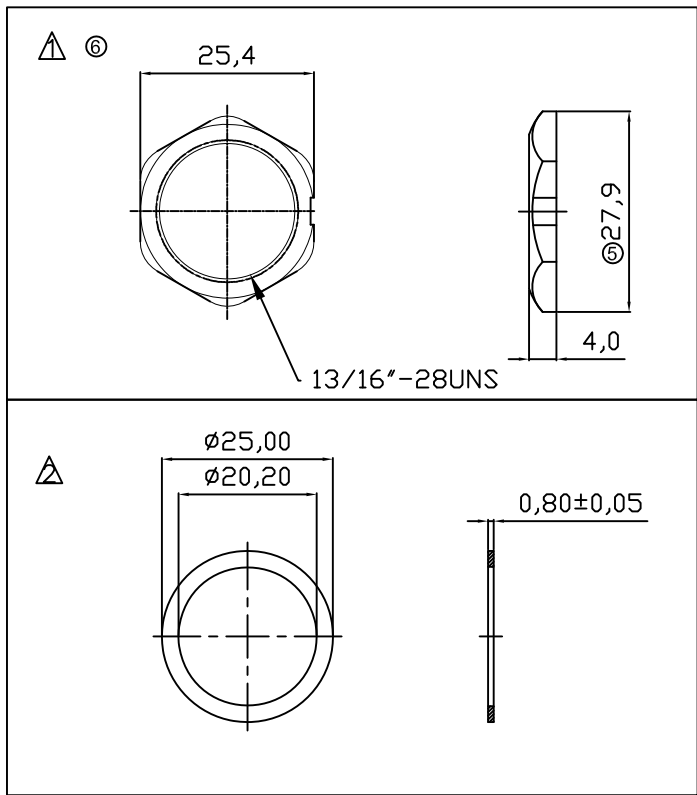

⑥ Notes:
Recommended use torque force: 1.0Nm Max.

△	PE Bag		1# transparent	1
△	Gasket	Black	EPDM UL94V-0 ⑤	1
△	Nut	Black	Nylon+GF UL94V-0 ⑤	1
NO	NAME	COLOR	SPECIFICATION	QTY ④

RoHS compliant
Unit: mm

Scale	Free	⑥	Update the nut and add the notes	07.12.2020	Segal		Date	Name	Customer-No.
TOLERANCE		⑤	Update PE bag size and add notes	03.04.2018	Amy	Drawn	06.01.2006	Hellwig	ASSMANN WSW-No. A-ACCSET-1
X.X	±0.25	④	Update-remove note	06.03.2015	Hellwig	Approved	07.12.2020	Segal	
X.XX	±0.10	③	Add tolerance	22.05.2013	Amy				
X.XXX	±0.05	②	Update	28.06.2010	Alex				
DIM	TOL	①	Drawn	06.01.2006	Hellwig				Drawing-No.
ANGLE	±1°								ASS 0534 C0
Angle	TOL	Id.	Modification	Date	Name				rev06
									Replace

