

RoHS compliant

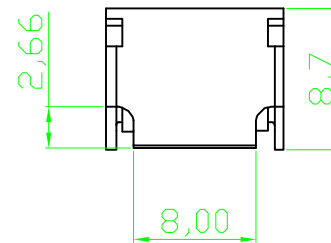

Material: Spring steel t0.6mm(SK85M)
 Finish: Nickel plated
 Federkraft/spring force ca.50N

Scale	FREE	Date	26.09.2008	Name	N.Schulz
TOLERANCE		Drawn	26.09.2008	Name	N.Schulz
UNIT	±0.3	Approved	10.03.2010	Name	Plate
	④	Modify drawing layout	10.03.2010	Dean	Approved
	③	Update	25.06.2009	N.Schulz	
	②	Update	30.04.2009	N.Schulz	
	①	Drawn	26.09.2008	N.Schulz	
DIM	TOL	Id.	Modification	Date	Name
X.°	±X°				
X.X°	±X°				
Angle	TOL				

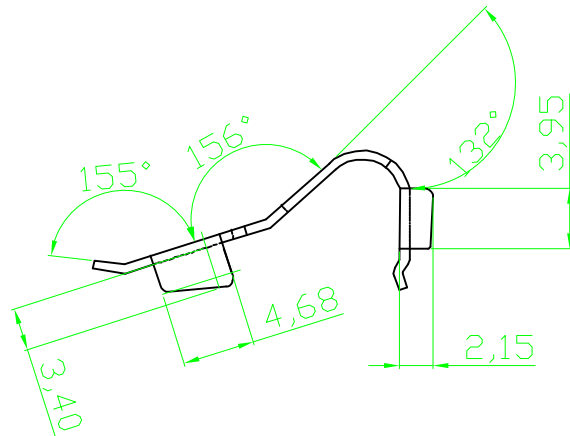
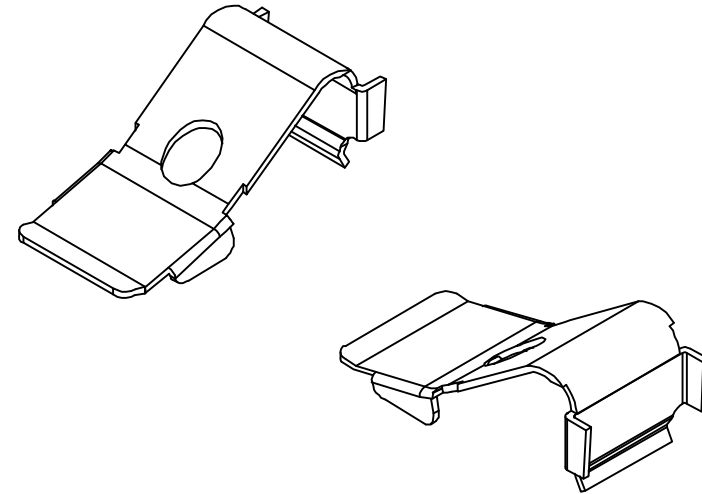
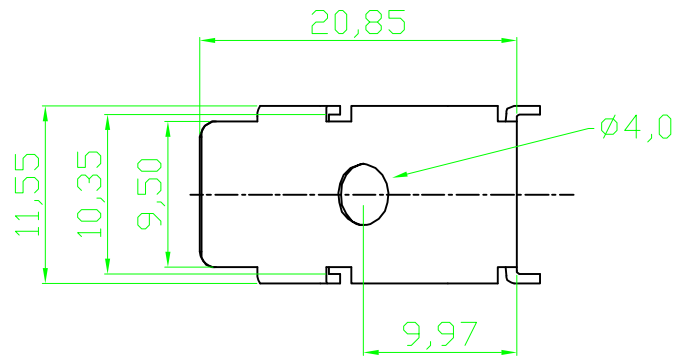

Customer-No.	
ASSMANN WSW-No. V220HK	
Drawing-No.	rev04
Replace	Sheet

1

2

3

4

5

6

7

KT932