

1

2

3

4

5

6

7

A

A

B

B

C

C

D

D

E

E

F

F

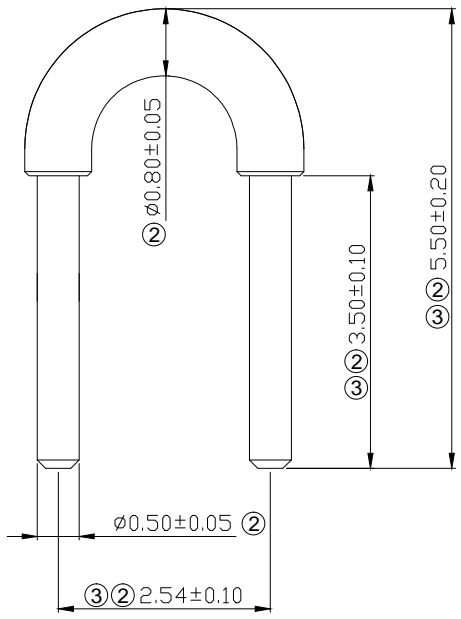

NOTE:

- 1.MATERIAL:Brass
- 2.Plating: Au 4u" over Nickel

G

G

RoHS compliant  
unit:mm

Scale	Free
TOLERANCE	
X.	±0.20
X.X	±0.15
X.XX	±0.10
X.XXX	±0.05
DIM	TOL
X°	±5°
Angle	TOL

							Date	Name	Description: Jumper Pin
							Drawn	09.09.2009	Dean
							Approved	01.25.2024	Peter
		③	Update the tolerance	01.25.2024	Peter				ASSMANN WSW-NO.  AB 7
		②	Change the plant and tolerance	12.11.2023	Peter				
		①	Drawn	09.09.2009	Dean				Drawing-No.
		Id.	Modification	Date	Name				ASS 3693 CO
									rev03
									Customer-No.
									Sheet 1 / 1



1

2

3

4

5

6

7

H

H