

1

2

3

4

5

6

7

A

A

B

B

C

C

D

D

E

E

F

F

G

G

H

H

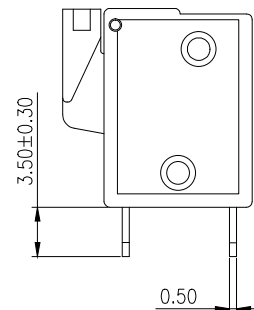
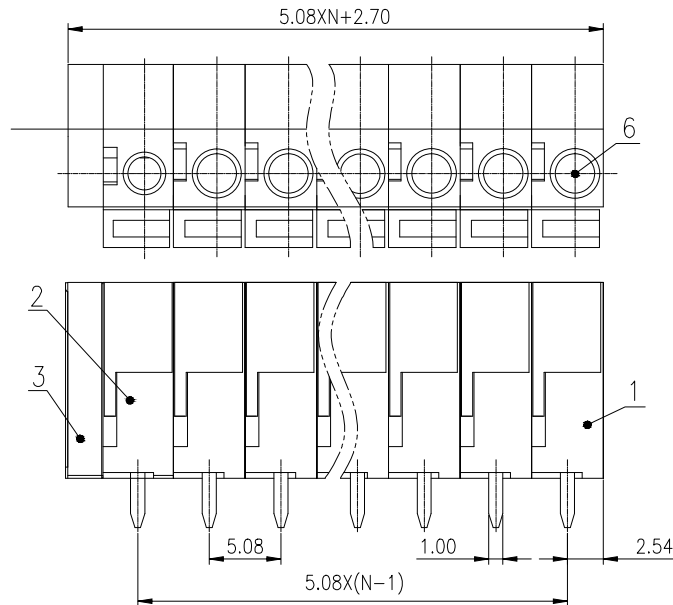
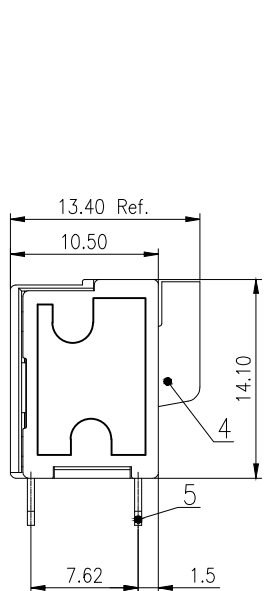

## Material

Item (1) housing 1: PA66 (UL94V-0),Green  
 Item (2) housing 2: PA66 (UL94V-0),Green  
 Item (3) Cover: PA66 (UL94V-0),Green  
 Item (4) Button: PA66 (UL94V-0)  
 Item (5) Contact:Copper Allpy,Tin plated

## Electrical

Voltage rating: 300V/320V  
 Current rating: 10A/15A  
 Wire range:0.2-1.5mm<sup>2</sup>  
 Solid wire(AWG): 16-22  
 Stranded wire(AWG):16-22  
 Wire strip length: 10mm  
 Withstanding Voltage: 1.6KV/2KV  
 Operating temperature: -40°C to +105°C  
 Wave Soldering temperature: 250°C±10°C/5 Sec

## PCB LAYOUT

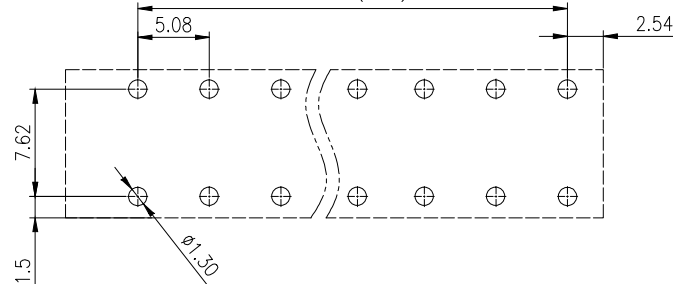

DIM	≤6	>6-10	>10-24	≤30	>30-60	>60-100	>100-150	>150
TOL	±0.10	±0.15	±0.25	±0.20	±0.30	±0.50	±0.70	±1.00

**RoHS compliant**  
Unit: mm

Scale	Free
TOLERANCE	
X.	±0.50
X.X	±0.40
X.XX	±0.20
DIM	TOL
X.°	±1°
Angle	TOL

Id.	Modification	Date	Name
①	Drawn	11.01.2023	Winnie

Date: 11.01.2023  
 Name: Winnie  
 Drawn: 11.01.2023  
 Approved: 11.01.2023  
 Winnie

**ASSMANN**  
WSW components  
A company of BCS

Description: Terminal Block Pitch 5.08mm ,THT	
ASSMANN WSW-No. A-TB0508-02CLA01-GN	
Drawing-No. <b>ASS 9698 CO</b>	rev00
Customer-No.	Sheet 1 / 1

1

2

3

4

5

6

7