

1

2

3

4

5

6

7

A

A

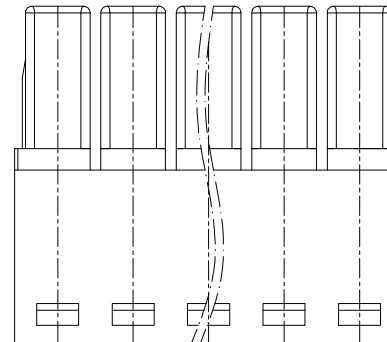
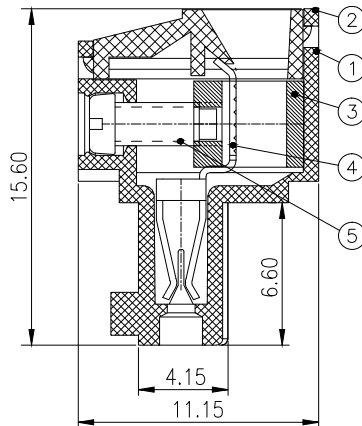
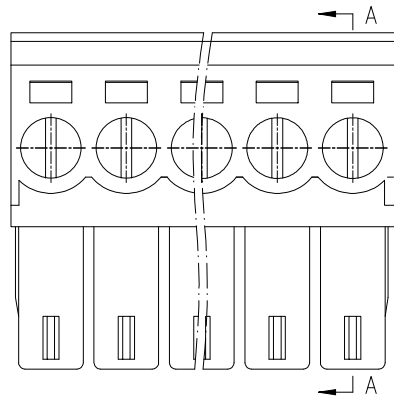

BOTTOM VIEW

SECTION: A-A

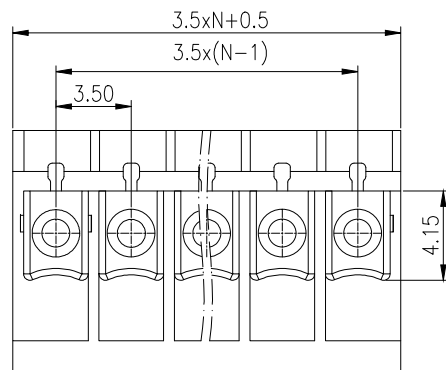

Without the rib when the poles number more than 6

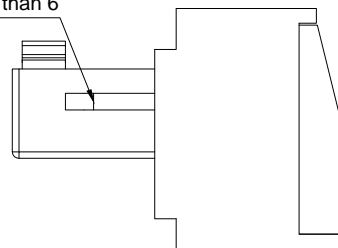

Note:

1.Material

- 1.1 Item (1) Housing:PA66,UL 94V-0
- 1.2 Item (2) Cover:PA66,UL 94V-0
- 1.3 Item (3) Clamp:Brass,Ni plated
- 1.4 Item (4) Contact:Phosphor Bronze,Ni plated
- 1.5 Item (5) Screw:M2 Steel,Zinc plated

2.Electrical

- 2.1 Voltage Rating:300V/250V
- 2.2 Current Rating:8A/7A
- 2.3 Contact Resistance:20mΩ
- 2.4 Insulation Resistance:5000MΩ Min.
- 2.5 Withstanding Voltage:2000V AC/1Min

3.Wire Range:28-16AWG,1.5mm²

4.Strip Length:7-8mm

5.Tighten Torque:0.2N·m

6.Operating temperature: -40°C to +105°C

① Order Code:A-TB0350-xxSRG01-xx

- GN:Green
- GY:Gray

B

C

D

E

F

DIM	≤6	>6~10	>10~24	≤30	>30~60	>60~100	>100~150	>150
TOL	±0.10	±0.15	±0.25	±0.20	±0.30	±0.50	±0.70	±1.00

RoHS compliant
Unit: mm

Scale Free

TOLERANCE

DIM TOL

Angle TOL

①	Add the P/N	02.20.2024	Peter
②	Drawn	11.03.2023	Winnie
Id.	Modification	Date	Name



Date	Name
11.03.2023	Winnie
02.20.2024	Peter

Description: Terminal Block
Pitch 3.50mm

ASSMANN WSW-No.
① A-TB0350-xxSRG01-xx

Drawing-No.
ASS 9704 CO rev01

Customer-No.
Sheet 1 / 1

1

2

3

4

5

6

7

H