

1

2

3

4

5

6

7

A

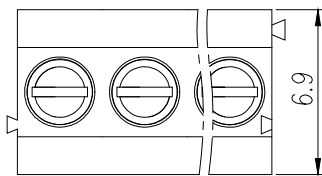

B

C

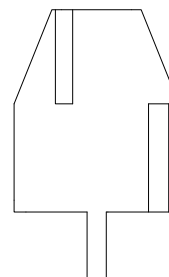
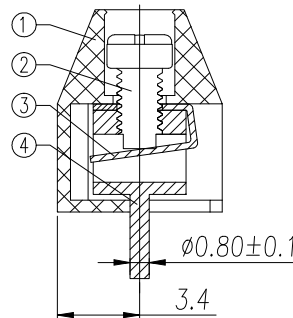
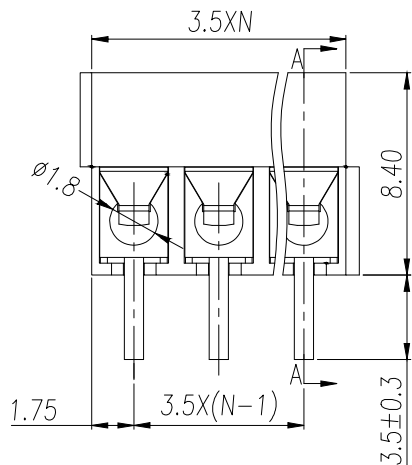
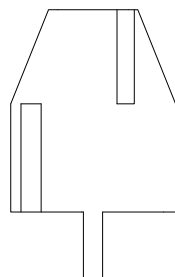

Note:

1.Material

- 1.1 Item (1) Housing:PA66,UL 94V-0,Black
- 1.2 Item (2) Screw:Steel,Zinc plated
- 1.3 Item (3) Wire Guard:Phosphor Bronze,Ni plated
- 1.4 Item (4) Contact Pin:Brass,Tin Plated

2.Electrical

- 2.1 Voltage Rating:300V
- 2.2 Current Rating:7A
- 2.3 Contact Resistance:20mΩ
- 2.4 Insulation Resistance:5000MΩ/1000V
- 2.5 Withstanding Voltage:2000V AC/1Min

3.Wire Range:22-18AWG 1mm<sup>2</sup>

- 4.Strip Length:5mm
- 5.Tighten Torque:0.2N·m
- 6.Operating Temperature: -40°C to +105°C
- 7.Wave Soldering Temperature:+250°C Max.5S

D

E

F

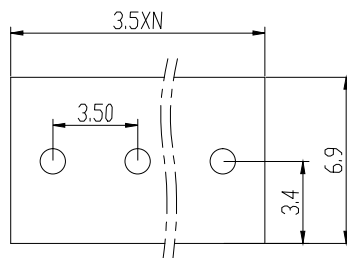

P.C.B LAYOUT

DIM	≤6	>6-30	>30-120	>120-480	>480
TOL	±0.10	±0.20	±0.30	±0.50	±0.90

G

RoHS compliant  
Unit: mm

Scale Free

TOLERANCE

Date

Name

Description: Terminal Block

Pitch 3.50mm THT

Drawn

11.03.2023

Winnie

Approved

11.03.2023

Winnie

ASSMANN WSW-No.

A-TB0350-xxCWA01-BK

H

DIM TOL

①

Drawn

11.03.2023

Winnie



Drawing-No.

ASS 9710 CO

rev00

Customer-No.

Sheet 1 / 1

1

2

3

4

5

6

7

A

B

C

D

E

F

G

H