

Product Change Notification(PCN)

Issue Date: 26.06.2019
Modification / Revision Date: 26.06.2019

A-PCMCIA-68-F-x-x-003

Compact Flash Receptacle Clip Memory Card conn.

Change Notification: PCN 20190618 A-PCMCIA-68-F-x-x-003

Description of changes:

1. Update packing, plating, and dimensions
2. Draw.-No. ASS_3646_COrev02 substitutes ASS_3646_COrev01
3. Change to A-PCMCIA-68-F-1-S-003

Date of change and Implementation: Change: Week 26 / 2019
Implementation: 26.06.2019

Key Characteristics of Change: Update packing, plating, and dimensions, see page 3

Products Affected: A-PCMCIA-68-F-x-x-003

Reason for Change: Update packing, plating, and dimensions

Response : No response to this notification is required.

PCN Revision History:

Date of Revision: 26.06.2019

Revision Number: 00

page 1/

Auf dem Schüffel 1
D-58513 Lüdenscheid
Tel.: +49-2351 - 554-0
Fax +49 (2351) 554-861
info@assmann-wsw.com
www.assmann-wsw.com

Product Change Notification(PCN)

Issue Date: 26.06.2019
Modification / Revision Date: 26.06.2019

Reference Documents / Attachments:

Document: Drawing

| ASSMANN WSW P/N | Drawing Number |
|-----------------------|------------------|
| A-PCMCIA-68-F-x-x-003 | ASS_3646_COrev02 |

PCN Revision History:

Date of Revision: 26.06.2019

Revision Number: 00

page 2/

Product Change Notification(PCN)

Issue Date: 26.06.2019
 Modification / Revision Date: 26.06.2019

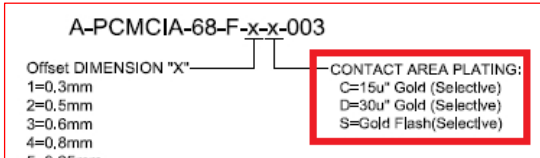
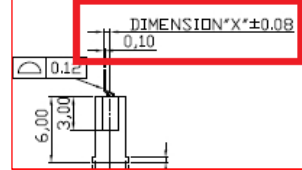
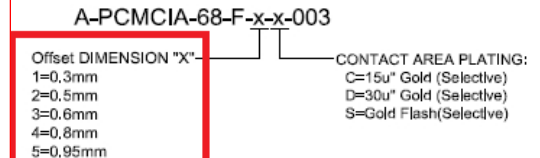
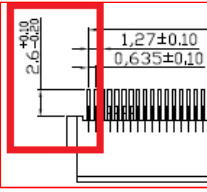
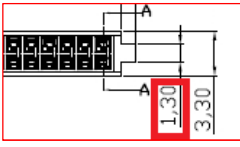
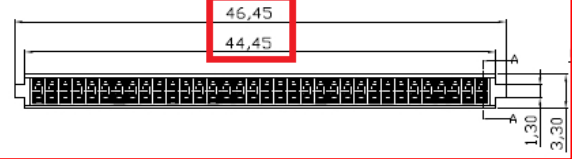
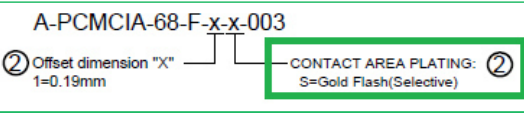
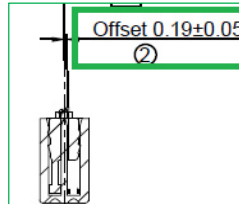
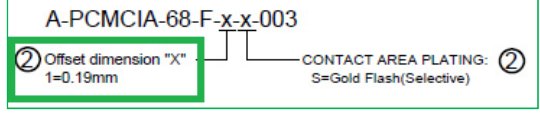
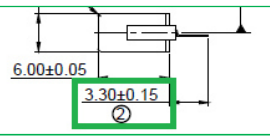
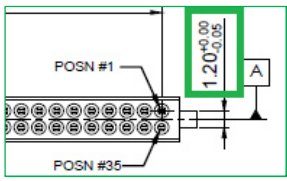
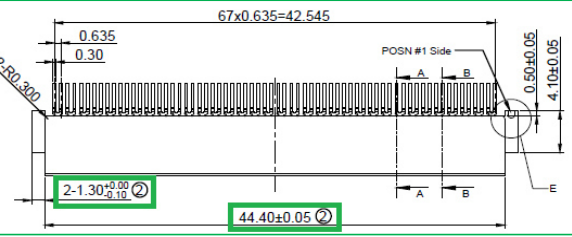
| A-PCMCIA-68-F-x-x-003 Old version | A-PCMCIA-68-F-x-x-003 New version |
|--|---|
| <p>1. Plating option</p> <p>Contact Area: 1u"~30u" Selective Gold</p>  <p>2. Packing type</p> <p>Packing : Tube</p> <p>3. Offset dimension option</p>   <p>4. Dimensions</p> <p>4-1</p>  <p>4-2</p>  <p>4-3</p>  | <p>1. Plating option</p> <p>Contact Area: Gold flash (Selective Gold)</p>  <p>2. Packing type</p> <p>Packing : Tray</p> <p>3. Offset dimension option</p>   <p>4. Dimensions</p> <p>4-1</p>  <p>4-2</p>  <p>4-3</p>  |
| <p>For detail, please take attached new drawing: ASS_3646_Corev02 for reference</p> | |

PCN Revision History:

Date of Revision: 26.06.2019

Revision Number: 00

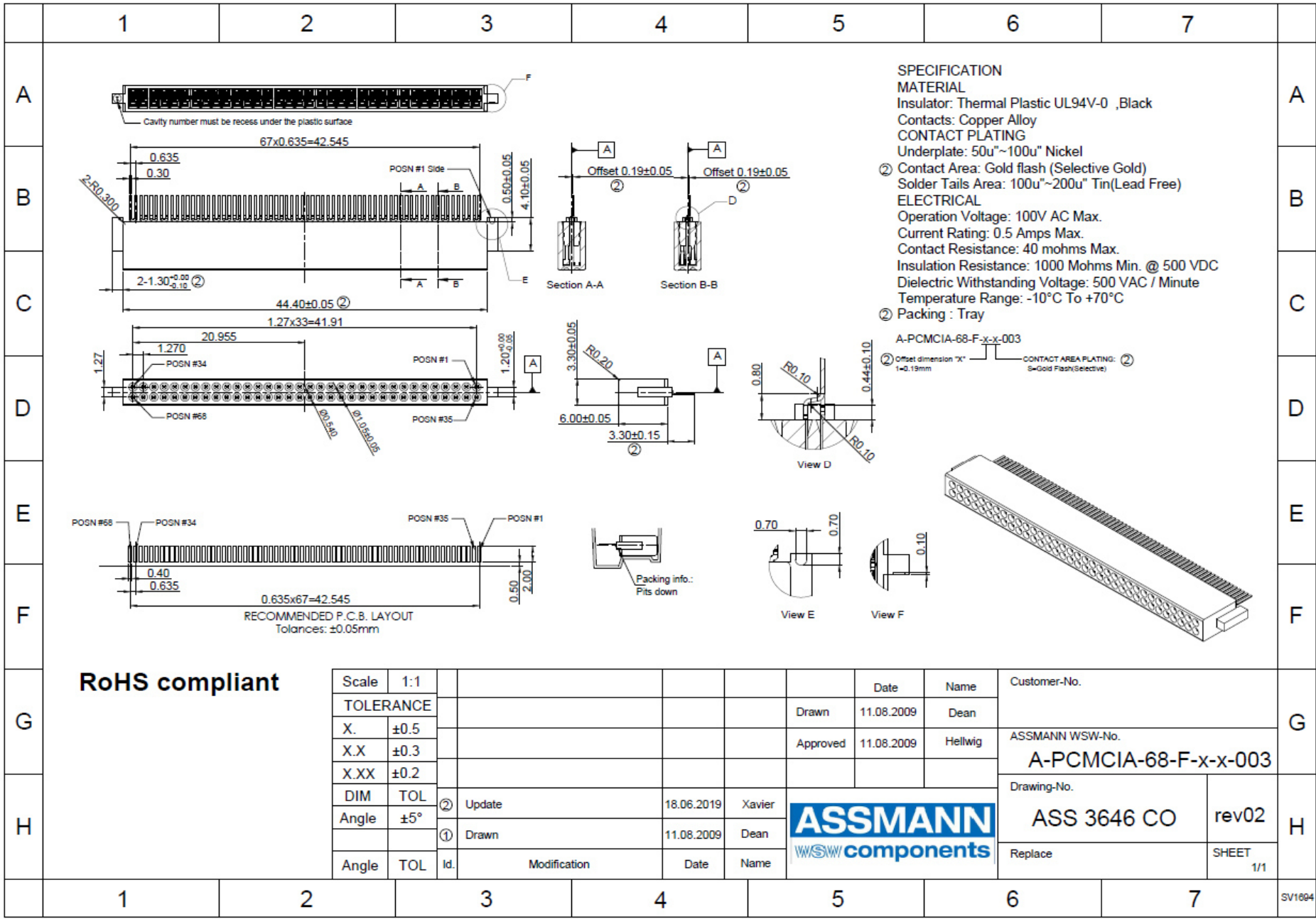

SPECIFICATION
MATERIAL
 Insulator: Thermal Plastic UL94V-0 ,Black
 Contacts: Copper Alloy
CONTACT PLATING
 Underplate: 50u"~100u" Nickel
 ② Contact Area: Gold flash (Selective Gold)
 Solder Tails Area: 100u"~200u" Tin(Lead Free)
ELECTRICAL
 Operation Voltage: 100V AC Max.
 Current Rating: 0.5 Amps Max.
 Contact Resistance: 40 mohms Max.
 Insulation Resistance: 1000 Mohms Min. @ 500 VDC
 Dielectric Withstanding Voltage: 500 VAC / Minute
 Temperature Range: -10°C To +70°C
 ② Packing : Tray
 A-PCMCIA-68-F-x-x-003
 ② Offset dimension "X"
 1=0.19mm
 S=Gold Flash(Selective) ②

RoHS compliant

| | | | | | | | | | | | | | |
|-----------|------|-----|--------------|------------|--------|--|--|--|--|--|--|--|--|
| Scale | 1:1 | | | | | | | | | | | | |
| TOLERANCE | | | | | | | | | | | | | |
| X. | ±0.5 | | | | | | | | | | | | |
| X.X | ±0.3 | | | | | | | | | | | | |
| X.XX | ±0.2 | | | | | | | | | | | | |
| DIM | TOL | ② | Update | 18.06.2019 | Xavier | | | | | | | | |
| Angle | ±5° | ① | Drawn | 11.08.2009 | Dean | | | | | | | | |
| Angle | TOL | Id. | Modification | Date | Name | | | | | | | | |



| | | |
|-------------|---------|------------------------------|
| Date | Name | Customer-No. |
| 11.08.2009 | Dean | |
| 11.08.2009 | Hellwig | ASSMANN WSW-No. |
| | | A-PCMCIA-68-F-x-x-003 |
| Drawing-No. | | |
| ASS 3646 CO | rev02 | |
| Replace | SHEET | |
| | 1/1 | |