



PRODUCT CHANGE NOTIFICATION (PCN)

ISSUE DATE: 01.07.2021
MODIFICATION / REVISION DATE: 01.07.2021

V4094 / V4433 / V4538R / V4548 / V4555 / V4718
Accessories, mounting pads

CHANGE NOTIFICATION: PCN 20210701_V4094_V4433_V4538R_V4548_V4555_V4718

DESCRIPTION OF CHANGES: CHANGE OF PRODUCT MATERIALS

REASON FOR CHANGE: CHANGE OF MATERIAL PARAMETERS OR PROPERTIES

KEY CHARACTERISTICS OF CHANGE: Details see page 2 & 3

PRODUCTS AFFECTED: V4094 / V4433 / V4538R / V4548 / V4555 / V4718
Accessories, mounting pads

DATE OF CHANGE AND IMPLEMENTATION: CHANGE: WEEK 26 / YEAR 2021
IMPLEMENTATION: 01.07.2021

RESPONSE: NO RESPONSE TO THIS NOTIFICATION IS REQUIRED



Auf dem Schüffel 1
D-58513 Lüdenscheid
Tel.: +49-2351 - 554-200
Fax +49 (2351) 554-861
info@assmann-wsw.com
www.assmann-wsw.com

PRODUCT CHANGE NOTIFICATION (PCN)

ISSUE DATE: 01.07.2021
MODIFICATION / REVISION DATE: 01.07.2021

REFERENCE DOCUMENTS / ATTACHMENTS:

ASSMANN WSW P/N	Drawing Number		ASSMANN WSW P/N	Drawing Number
V4094	ASS_0922_HSrev03	↔	V4094	ASS_0922_HSrev04
V4433	ASS_3952_HSrev00	↔	V4433	ASS_3952_HSrev01
V4538R	ASS_0921_HSrev03	↔	V4538R	ASS_0921_HSrev04
V4548	ASS_0923_HSrev03	↔	V4548	ASS_0923_HSrev04
V4555	ASS_0924_HSrev04	↔	V4555	ASS_0924_HSrev05
V4718	ASS_0925_HSrev03	↔	V4718	ASS_0925_HSrev04



Auf dem Schüffel 1
 D-58513 Lüdenscheid
 Tel.: +49-2351 - 554-200
 Fax +49 (2351) 554-861
 info@assmann-wsw.com
 www.assmann-wsw.com

PRODUCT CHANGE NOTIFICATION (PCN)

ISSUE DATE: 01.07.2021
 MODIFICATION / REVISION DATE: 01.07.2021

V4xxx OLD VERSION	V4xxx NEW VERSION
<p>Material : POLYPROPYLEN</p>	<p>Material : PA 6</p>
<p>FOR DETAIL, PLEASE TAKE ATTACHED NEW DRAWING: FOR REFERENCE</p>	

PCN REVISION HISTORY:

DATE OF REVISION: 01.07.2021

REVISION NUMBER: 00

RoHS compliant

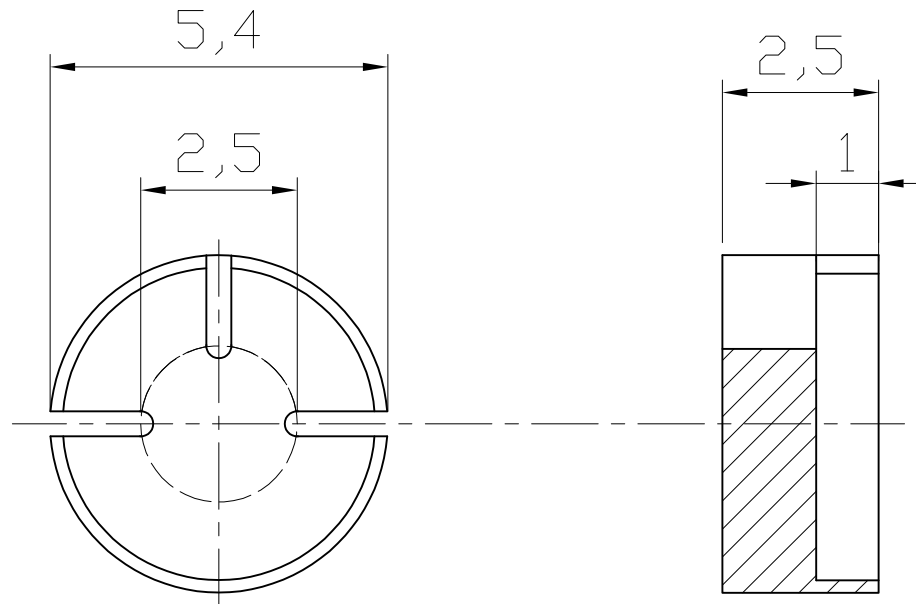

RoHS compliant
Unit:mm

Material : PA 6

Scale	free					Date	Name	Customer-No.
TOLERANCE					Drawn	20.08.2009	Dean	
X.	±X	④	Change Material	01.07.2021	Larsen	Approved	01.07.2021	Larsen
X.X	±X	③	Material add.	31.05.2011	Schulz			
X.XX	±X	②	Modify drawing layout	10.03.2010	Alex			
DIM	TOL	①	Drawn	20.08.2009	Dean			
X.°	±X°							Drawing-No.
X.X°	±X°							ASS 0921 HS
Angle	TOL	Id.	Modification	Date	Name			rev04
								Replace
								Sheet

V4538R



ASS 0921 HS

rev04

Replace

Sheet

RoHS compliant

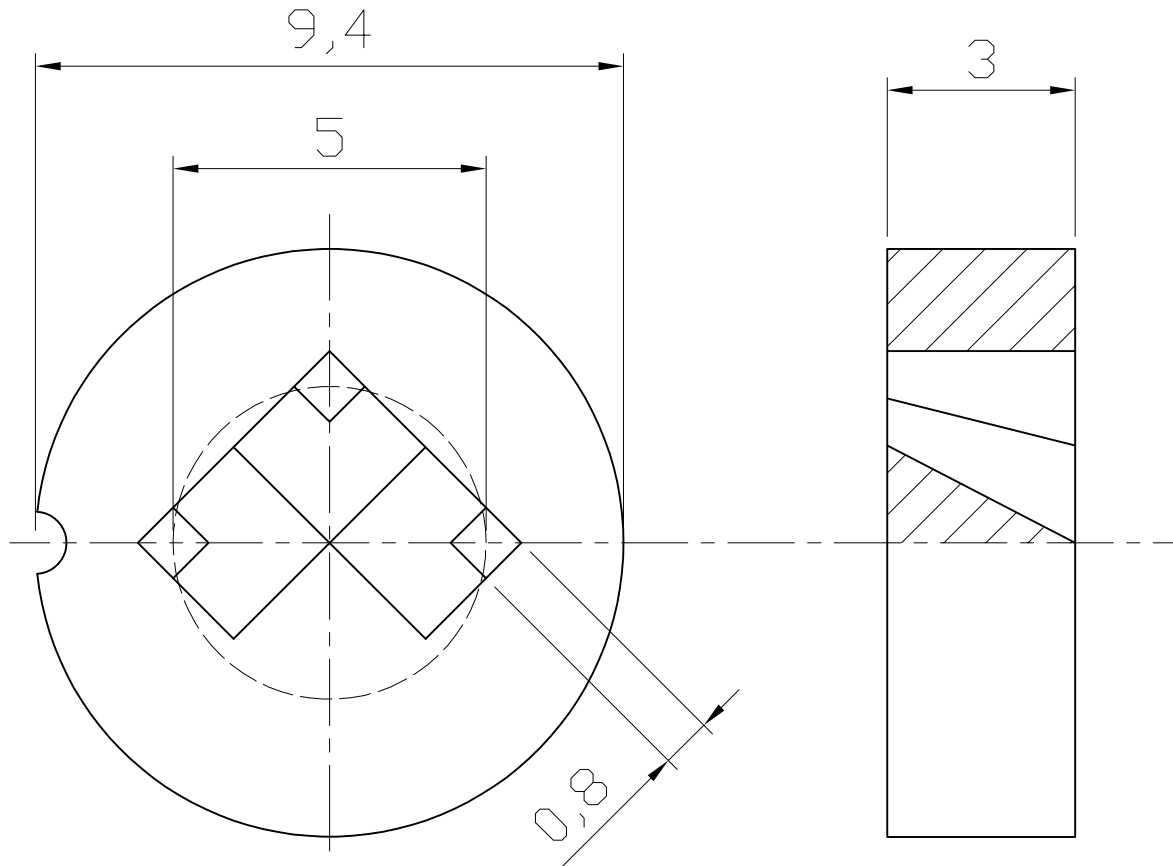

RoHS compliant
Unit:mm

Material : PA 6

Scale	free					Date	Name	Customer-No.
TOLERANCE					Drawn	20.08.2009	Dean	
X.	±X	④	Change Material	01.07.2021	Larsen	Approved	01.07.2021	Larsen
X.X	±X	③	Material add.	31.05.2011	Schulz			
X.XX	±X	②	Modify drawing layout	10.03.2010	Alex			
DIM	TOL	①	Drawn	20.08.2009	Dean			
X.°	±X°							
X.X°	±X°							
Angle	TOL	Id.	Modification	Date	Name			

ASSMANN WSW components		Drawing-No.	ASS 0922 HS	rev04
		Replace		Sheet



V4094

ASS 0922 HS rev04

Replace Sheet

RoHS compliant

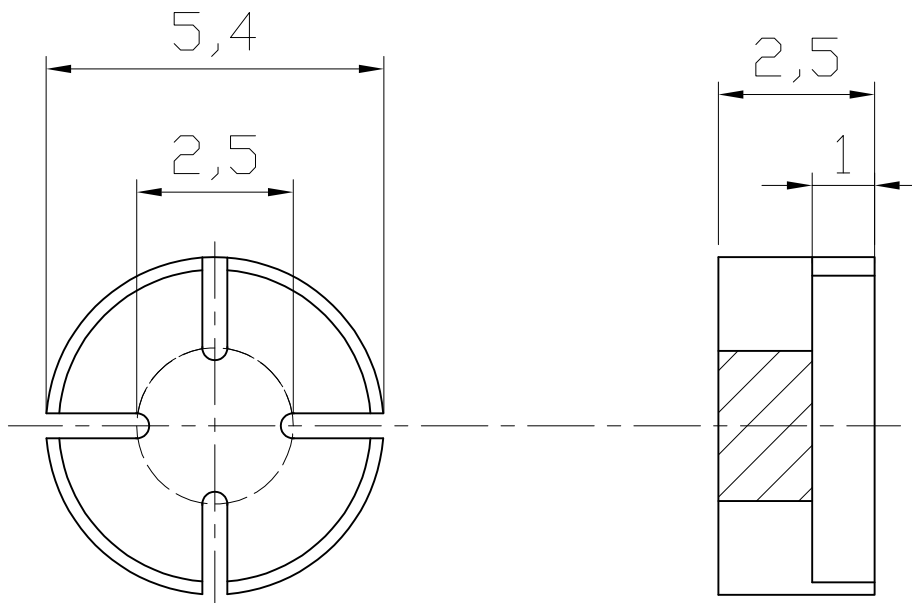

RoHS compliant
Unit:mm

Material : PA 6

Scale	free					Date	Name	Customer-No.
TOLERANCE					Drawn	20.08.2009	Dean	ASSMANN WSW-No. V4548
X.	±X	④	Change Material	01.07.2021	Larsen	Approved	Larsen	
X.X	±X	③	Material add.	31.05.2011	Schulz			
DIM	TOL	②	Modify drawing layout	10.03.2010	Alex			Drawing-No.
X.°	±X°	①	Drawn	20.08.2009	Dean			ASS 0923 HS
X.X°	±X°							Replace
Angle	TOL	Id.	Modification	Date	Name			Sheet



RoHS compliant

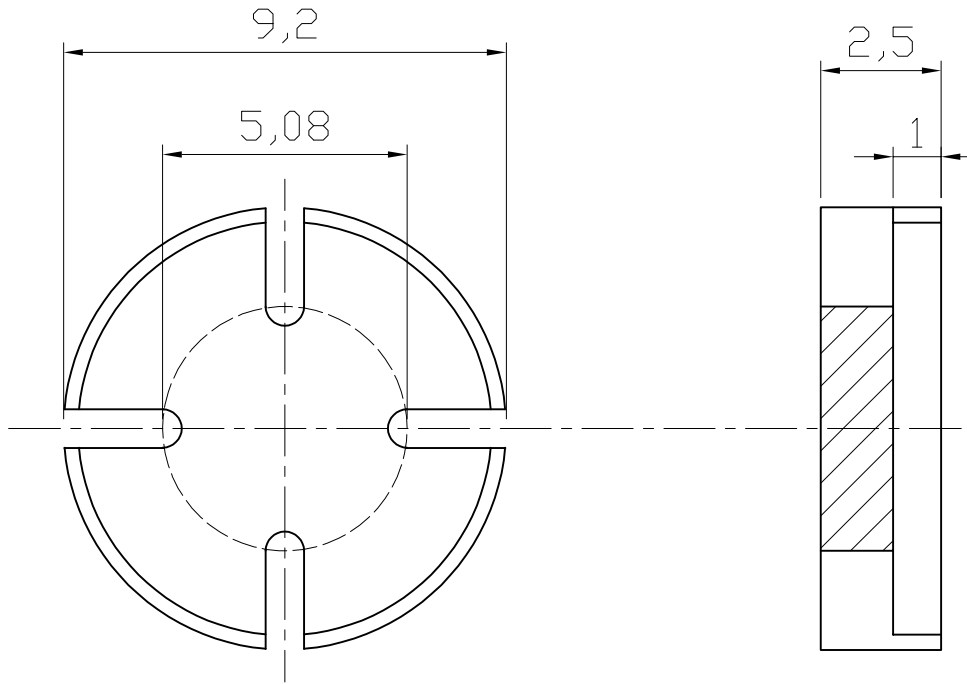

RoHS compliant
Unit:mm

Material : PA 6

Scale	1:1					Date	Name	Customer-No.	
TOLERANCE		⑤	Change Material	01.07.2021	Larsen	Drawn	20.08.2009	ASSMANN WSW-No. V4555	
X.	±X	④	Material specifications add.	23.10.2019	Lübke	Approved	01.07.2021		
X.X	±X	③	Material add.	31.05.2011	Schulz				
DIM	TOL	②	Modify drawing layout	10.03.2010	Alex			Drawing-No.	
X.°	±X°	①	Drawn	20.08.2009	Dean			ASS 0924 HS	rev05
X.X°	±X°							Replace	Sheet 1/1
Angle	TOL	Id.	Modification	Date	Name				



Customer-No.	
ASSMANN WSW-No.	V4555
Drawing-No.	ASS 0924 HS
Replace	Sheet 1/1

1 2 3 4 5 6 7

A

A

B

B

C

C

D

D

E

E

F

F

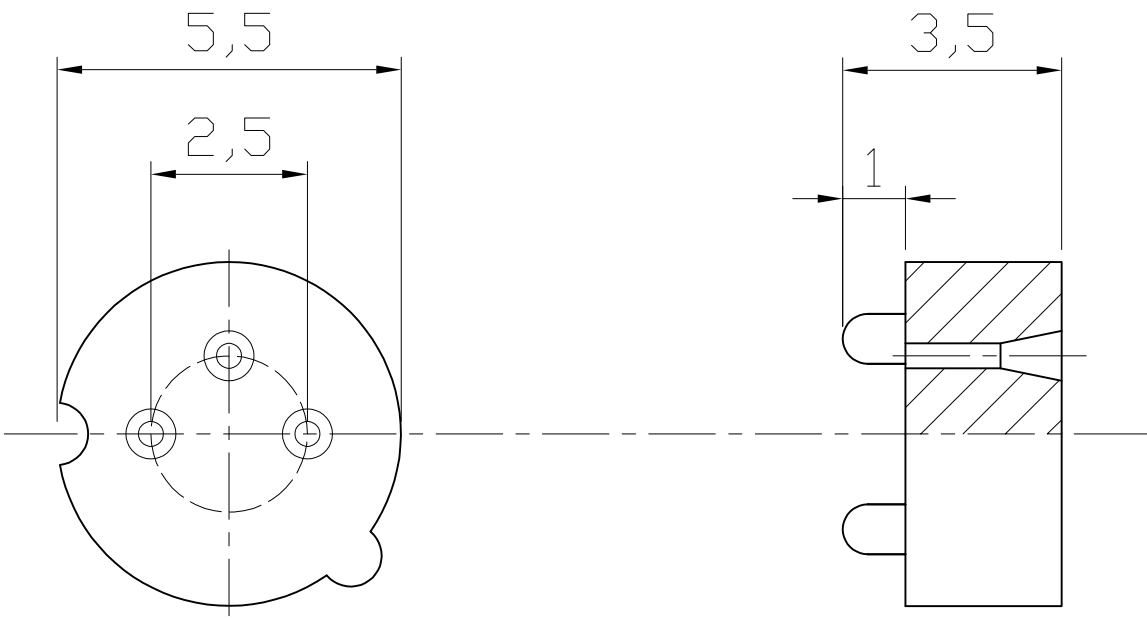

RoHS compliant
Unit:mm

Material : PA 6

Scale	1:1					Date	Name	Customer-No.
TOLERANCE					Drawn	20.08.2009	Dean	
X.	±X	④	Change Material	01.07.2021	Larsen	Approved	01.07.2021	Larsen
X.X	±X	③	Material add.	31.05.2011	Schulz			
X.XX	±X	②	Modify drawing layout	10.03.2010	Alex			
DIM	TOL	①	Drawn	20.08.2009	Dean			
X.°	±X°							
X.X°	±X°							
Angle	TOL	Id.	Modification	Date	Name			

ASSMANN WSW-No. V4718

Drawing-No. ASS 0925 HS rev04

Replace Sheet



1 2 3 4 5 6 7

H

H

1 2 3 4 5 6 7

A

B

C

D

E

F

G

H

A

B

C

D

E

F

G

H

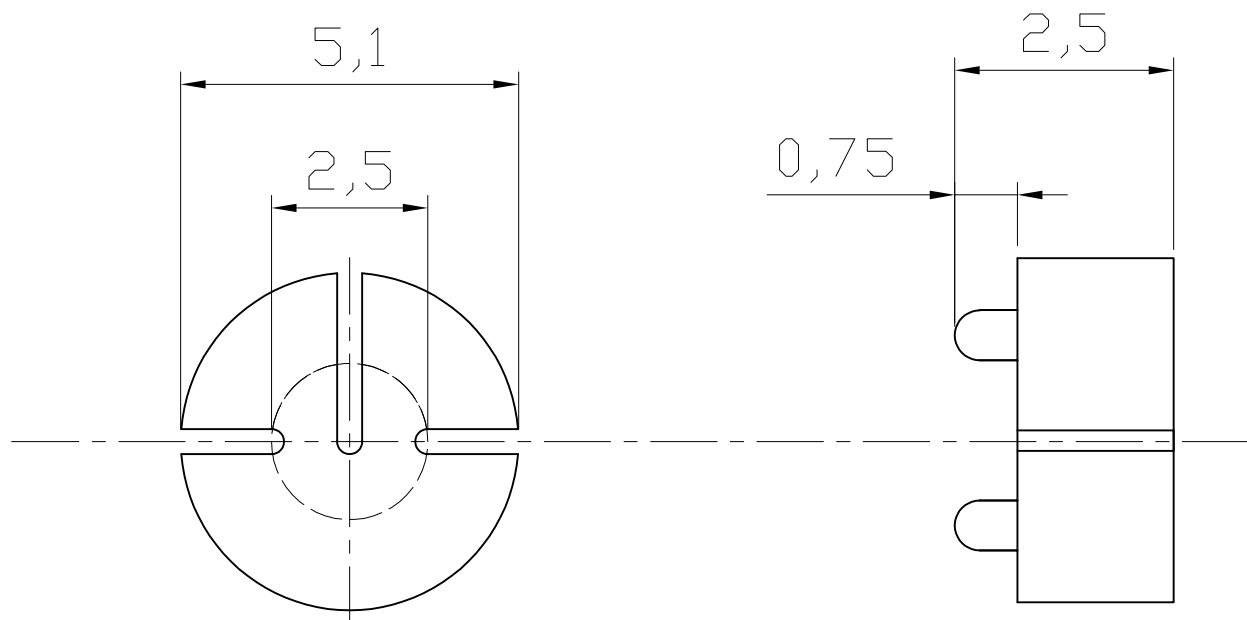

RoHS compliant
Unit:mm

Material : PA 6

Scale	1:1						Date	Name	Customer-No.	
TOLERANCE						Drawn	28.09.18	Florian		
X.	±X					Approved	01.07.2021	Larsen	ASSMANN WSW-No.	
X.X	±X								V4433	
X.XX	±X								Drawing-No.	
DIM	TOL	①	Modify layout / Change Material	01.07.2021	Larsen				ASS 3952 HS	rev01
X.°	±X°	②	Drawn	28.09.18	Florian				Replace	Sheet
X.X°	±X°									
Angle	TOL	Id.	Modification	Date	Name					

1 2 3 4 5 6 7