

ASSEMBLY INSTRUCTION

D-SUB COVER

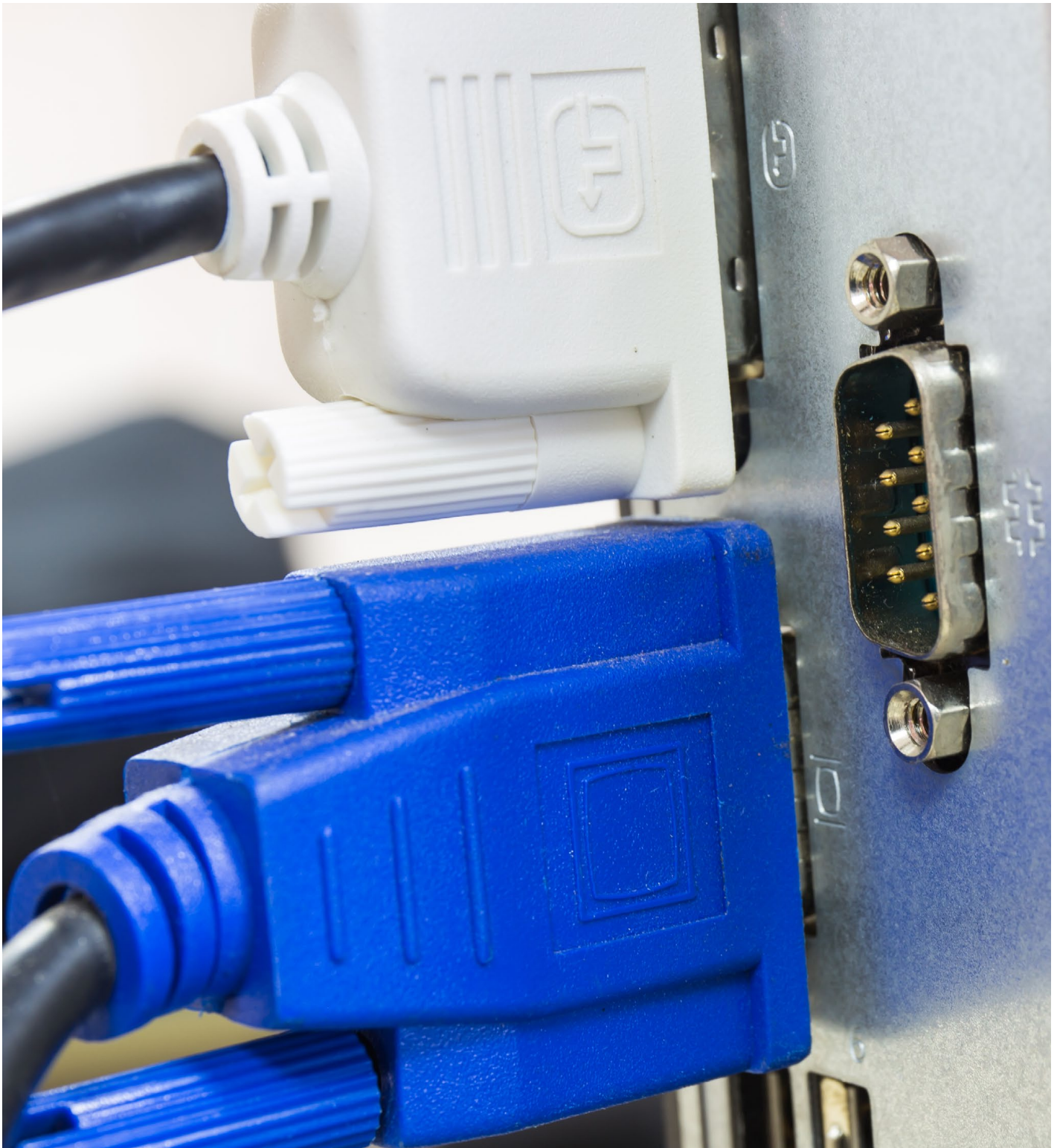

CONNECTORS

AMET-xx RS – ASSEMBLY INSTRUCTION

Drawing 1

Use two halves of strain relief. Different sizes can be mixed.

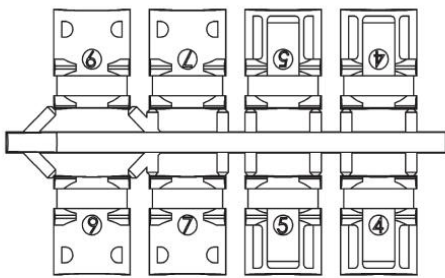

Drawing 2

Strip cable 18mm and shape cable to two pigtails.

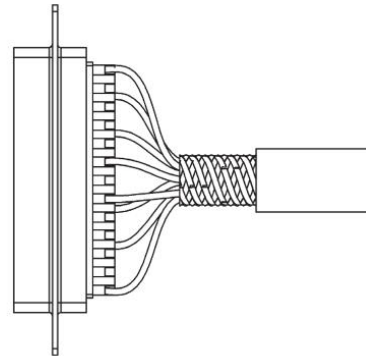

Drawing 3

Attach the strain relief around the cable.

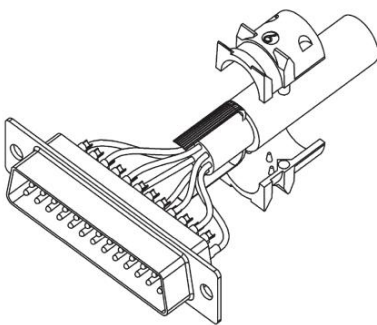

Drawing 4

Bend cable shielding back on outside of strain relief.

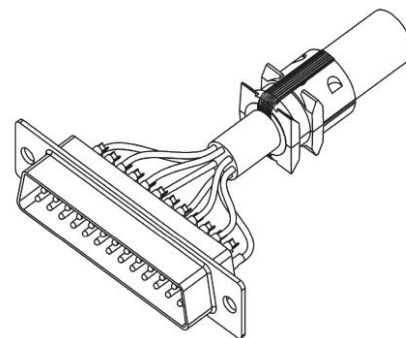

Drawing 5

Mount connector and cable into the shell.

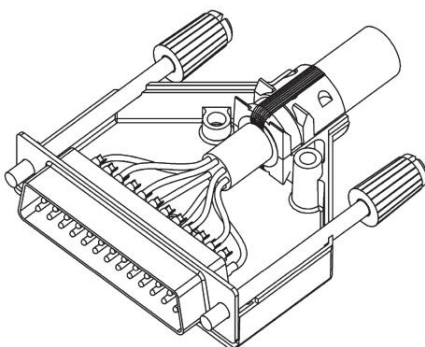

Drawing 6

Assemble the other half. Torque: 100 - 120 Ncm.

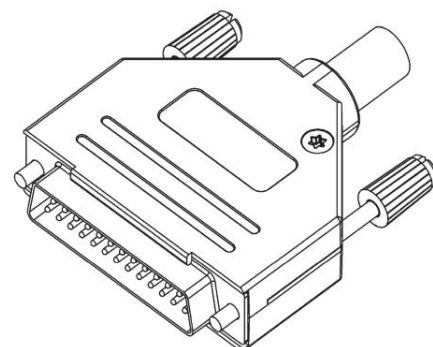

CONNECTORS

ACOV-SUB-xxMB40 – ASSEMBLY INSTRUCTION

Preparation

Prepare the cable by stripping 18-25 mm and shape the braid into two pigtails. If the cable has a drain wire, please leave about 55-60 mm to pull around the support clip.

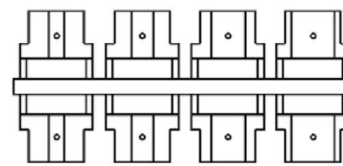
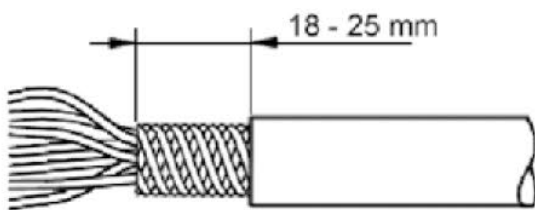

Strain relief



Support Clip

Foil cable with earth / drain wire:

Select the ferrule halves that most closely match the diameter of the cable. The halves of the strain reliefs do not need to match. Assemble the two halves around the cable and complete as shown in Fig. 2. Loop the earth wire preferably around the support clip. The earth wire can be insulated and extended to a contact on the connector if required.

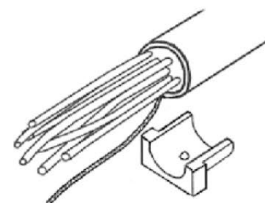

Fig. 1

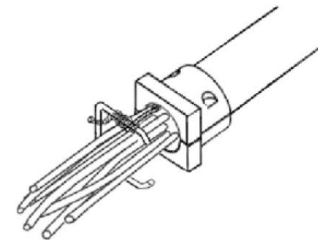

Fig. 2

Braided Cable

For heavily braided cables, pigtail the braid and turn it back over the Clip as shown in Fig. 3.

For light braided cables, pigtail the braid and turn it back over the Clip in one direction only.

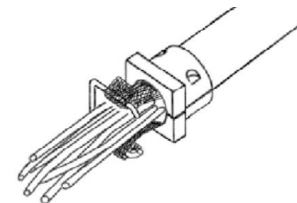

Fig. 3

Mount connector and cable into the shell as shown in Fig. 4.

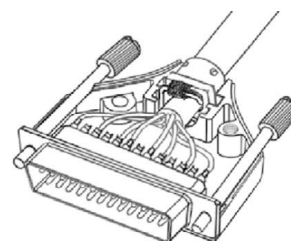

Fig. 4

Assemble the other half. Torque: 150 - 200 Ncm

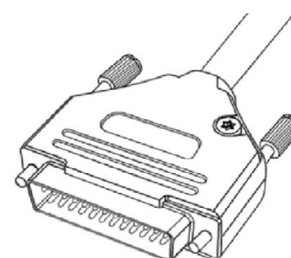

Fig. 5

ASSMANN

WSW components

A company of **BCS** GROUP

LEADING CUSTOMIZED CONNECTIVITY SOLUTIONS

CONNECTORS THERMAL MANAGEMENT CABLE ASSEMBLIES CAPABILITIES

ASSMANN WSW components GmbH

Auf dem Schüffel 1,
D-58513 Lüdenscheid,
Germany

Phone: +49 (23 51) 5542 - 00

ASSMANN WSW components k.s.

Zahradnicka 1135,
SK 958 03 Partizanske,
Slovakia

Phone: +421 (3874) 7 141 - 5

ASSMANN WSW components Inc.

1840 W. Drake Drive,
Suite 101, Tempe, AZ. 85283,
USA

Phone: +1 (480) 897 - 7001

ASSMANN WSW components Ltd.

Room 3A Jin Lian Xuan, Lotus Plaza No.126,
De Zheng Zhong RD, Changan Town,
Dongguan City, Guangdong 523847, China

Phone: +86 (769) 8 542 620 - 1